

PERFORMANCE DATA SHEET NEMA PREMIUM NR CAN NEMA 12 - 12

Catalogue #: **MPP-69**

HP	kW	Voltage	S.F. @ 60Hz	EFF.	P.F.	Frame	Design	L.R. Amps
60	44,76	575	1,15	92,4%	0,76	405T	B	348

60 Hz								
FLA							Code	F.L. RPM
208	230	416	460	480	575	600		
/	/	/	/	/	64	/	G	885

50 Hz							
FLA			S.F. @ 50Hz	Efficiency	Power Factor	Code	F.L. RPM
190	380	415					
/	/	/	/	/	/	/	/

Wgt. Lbs	PH	Duty	Insul. Class	Amb.	Elevation	Temp. Rise° C
1010	3	Cont.	F	40°C	1000M (3300 Ft)	< 80

% Efficiency		% Power Factor		Torque		Winding Resist. Ω	Safe Cold Start (Secs)
Full Load:	92,4%	Full Load:	0,76	Full Load Ft/Lbs	356,1		
3/4 Load:	92,4%	3/4 Load:	0,70	Locked Rotor %	200		
1/2 Load:	91,5%	1/2 Load:	0,60	Break Down %	245		

Rotor Inertia Wk2 Lb-Ft2	Max Load Inertia Wk2 Lb-Ft2	Shaft Material	Frame Material	DE Bracket Type	ODE Bracket Type	Enclosure	NEMA Rating	Lead Wire Size
30,85	1235	Standard	Cast Iron	Standard	Standard	TEFC	IP55	7AWG

Ball Bearings		Grease	Mount Type	Orientation	Paint	Sound Pressure @ 3FT	Sound Power
DE	ODE						
NU318	6314	Mobil PolyrexEm	Rigid	Horizontal	Green	76	82

Inverter Duty. Motor meets MG1 parts 31.4.4.2	Constant Torque Range	Variable Torque Range	Constant HP RPM
	10:1	20:1	1350

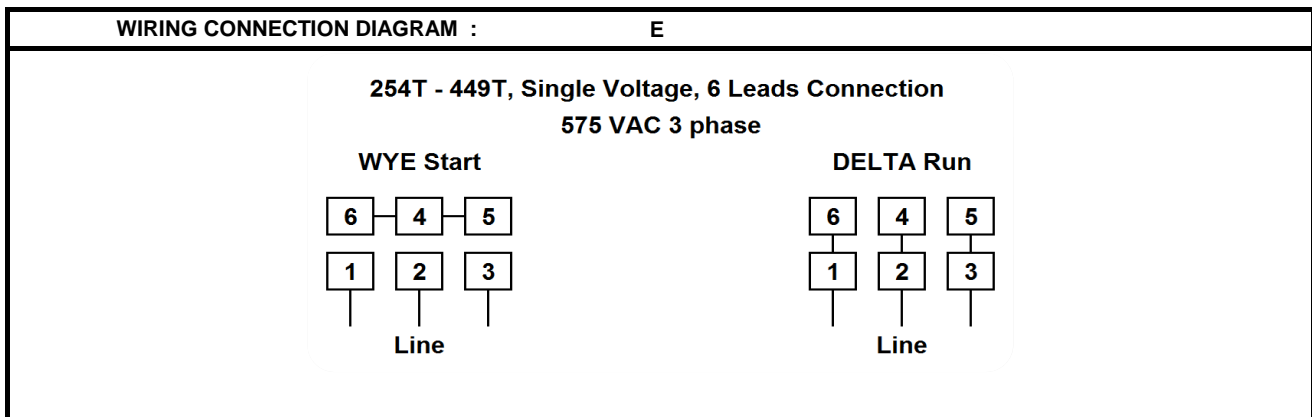

Date: 2020-02-27
 Customer: _____
 Contact: _____
 Submittee: J.C. Lavallée

Catalogue #: **MPP-69**

NEMA PREMIUM NR CAN NEMA 12 - 12										
HP	VAC	RPM	Enclosure	Frame	Frequency	Design	Poles	LR Code Letter	Insulation Class	Temp. Rise °C
60	575	885	TEFC	405T	60	B	8	G	F	< 80
	0Hz	6Hz	15Hz	30Hz	45Hz	60Hz	75Hz	90Hz	105Hz	120Hz
Amps	64	64	64	64	64	64	64	64	64	64
RPM	0	119	297,5	595	892,5	1190	1487,5	1785	2082,5	2380
Torq ft.lb	211,85	264,81	264,81	264,81	264,81	264,81	211,85	176,54	151,32	132,40
Peak Tq ft.lb	294,60	589,19	589,19	589,19	589,19	589,19	476,65	397,21	340,47	297,91
HP	0	6,0	15,0	30,0	45,0	60,0	60,0	60,0	60,0	60,0
	Locked Rotor	Pull-Up	Breakdown	Rated Load	Idle	Duty	S. F.	Ambient	Elevation	dBA @ 1M
Speed (RPM)	0,0	378	720	885	900	Continuous	1,15	40°C	3300 ft	76
Current (Amps)	348,0	295,8	207,1	64,0	22,4	VFD Rating: Meets MG1 parts 31.4.4.2				
Torque (ft-lbs)	529,6	397,2	648,8	264,8	0,0	C.T.	10:1	V.T.	20:1	

Motor Speed Data

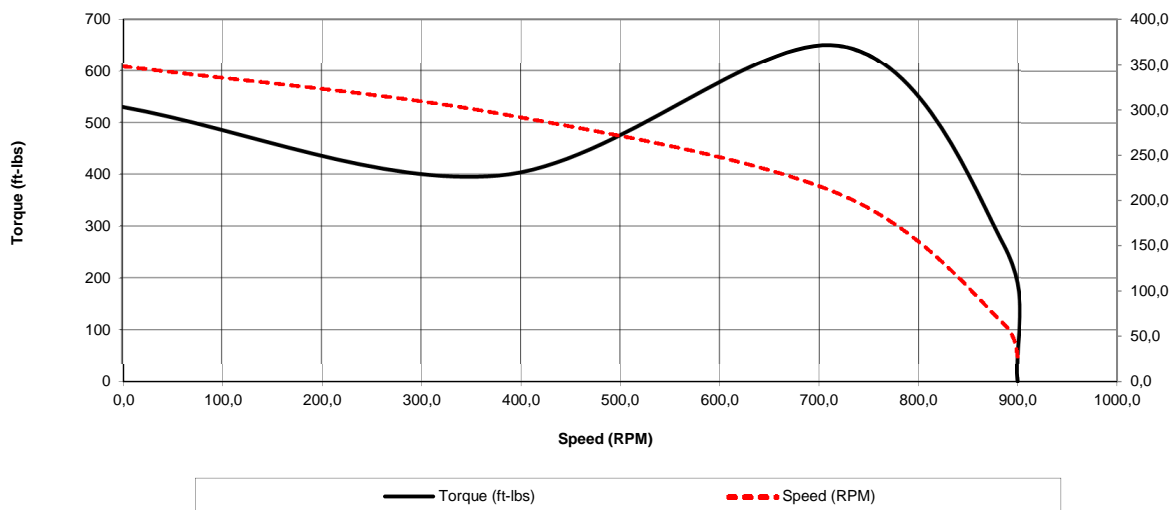

Motor Torque Capability vs RPM

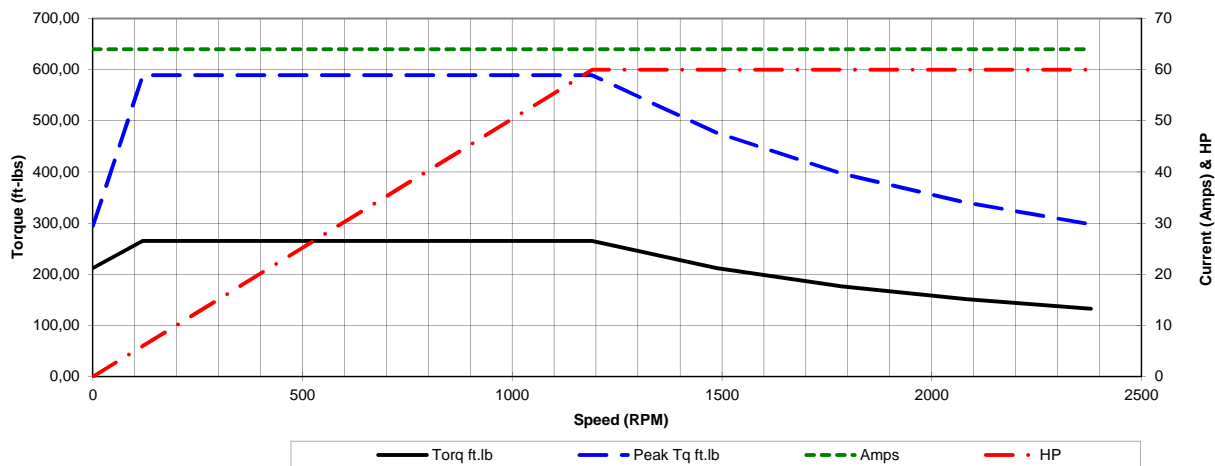



Date: 2020-02-27
 Customer: _____
 Contact: _____
 Submittee: J.C. Lavallée

Catalogue #: **MPP-69**

NEMA PREMIUM NR CAN NEMA 12 - 12										
HP	VAC	RPM	Enclosure	Frame	Frequency	Design	Poles	LR Code Letter	Insulation Class	Temp. Rise °C
60	575	885	TEFC	405T	60	B	8	G	F	< 80
Load %	0%	25%	50%	75%	100%	125%	150%			
Amps	22,40	25,60	35,14	48,96	64,00	77,95	91,20			
Torq ft/lbs	0	65,79	131,85	198,19	264,81	331,71	398,89			
RPM	0	1197,5	1195	1192,5	1190	1187,5	1185			
Eff	0	88,67	91,50	92,40	92,40	92,40	92,40			
PF	0	49,5	60	70	76	78	80			
	Locked Rotor	Pull-Up	Breakdown	Rated Load	Idle	Duty	S. F.	Ambient	Elevation	dBA @ 1M
Speed (RPM)	0	378	720	885	900	Continuous	1,15	40°C	3300 ft	76
Current (Amps)	348	295,8	207,1	64	22,4	VFD Rating: Meets MG1 parts 31.4.4.2				
Torque (ft-lbs)	529,61	397,21	648,78	264,81	0,0	C.T.	10:1	V.T.	20:1	

